

**NOTES:**

1. THE REARRANGEMENT OF THE AIRCRAFT LAYOUT FOR PASSENGER ACCOMMODATIONS IS TO BE PERFORMED IN ACCORDANCE WITH THIS DRAWING AND THE INSTRUCTIONS PROVIDED IN AIRE'S **SERVICE BULLETIN NO. A320C234-SB002**.
2. AISLE WIDTHS MUST MEET REQUIREMENTS SET FORTH IN JAR §25.815.
3. EMERGENCY EXITS MUST BE ACCESSIBLE PER JAR §25.813.
4. EMERGENCY EXITS MUST BE MARKED IN ACCORDANCE WITH JAR §25.811.
5. ALL LIFE VESTS MUST CONFORM TO J/E/TSO C-13.
6. CREW OXYGEN MASKS MUST MEET ALL REQUIREMENTS IN JAR §25.1439.
7. STORAGE PROVISIONS FOR ALL EMERGENCY EQUIPMENT MUST BE MARKED TO IDENTIFY THEIR CONTENTS IAW JAR §25.1561.
8. "FASTEN SEAT BELT" AND "NO SMOKING" SIGNS MUST BE VISIBLE TO EACH PERSON SEATED IN THE PASSENGER CABIN.
9. ALL SEAT BACKS AND BULKHEADS MUST HAVE "FASTEN SEAT BELT WHILE SEATED" PLACARD.
10. SEAT REFERENCE LINE IS TAKEN FROM POINT OF ATTACHMENT TO AIRCRAFT SEAT TRACKS.
11. ALL SEATS MUST CONFORM TO RESPECTIVE TSO/ETSO.
12. TIGHTEN THE REAR TRACK FITTING FASTENER AS PER SEATS' RESPECTIVE CMM INDICATION.
13. INSTALLATION AND SEATS TOLERANCE AS PER CMM.

**POST-INSTALLATION NOTES:**

- A. ENSURE EACH OXYGEN MASK DROPS WITHIN THE REQUIRED ZONE ABOVE PASSENGER SEAT.
- B. ENSURE NO SMOKING/FASTEN SEAT BELT SIGN IS VISIBLE TO EACH PASSENGER WHILE SEATED.
- C. ENSURE EMERGENCY ESCAPE PATH MARKING IS DIRECTLY VISIBLE ALONG THE WHOLE PASSENGER CABIN AND ALSO NO OBJECT OR CARPET COVERS IT AT ANY POINT OF EMERGENCY EXIT AISLES.
- D. REQUIRED AISLE WIDTH DIMENSIONS IN COMPLIANCE WITH JAR 25.
- E. SEATS AT FIRST ROWS ARE TO HAVE MINIMUM HEADSTRIKE CLEARANCE OF 35" FROM SEAT REFERENCE POINT.
- F. ENSURE THAT EACH SEAT HAS LIFE VEST INSTALLED.
- G. MAKE SURE THAT LIFE VEST LOCATION IS PROPERLY INDICATED IN A VISIBLE PLACE.

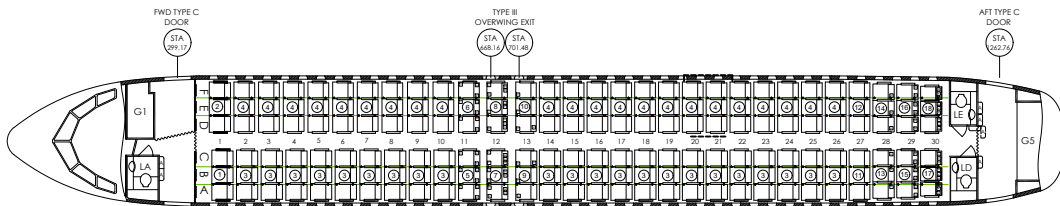

**FIGURE 1-B1. PASSENGER SEATS LAYOUT AFTER IMPLEMENTATION OF DESIGN CHANGE**

APPLICABILITY	
AIRCRAFT	MSN
AIRBUS A320-200	2233

REVISIONS				
ISSUE	DATE	REASON OF CHANGE	PREPARED BY	VERIFIED BY
1	15/12/2023	Initial Issue	DESIGN OFFICE	CVE

PART LIST			
ITEM	PART NUMBER	DESCRIPTION	QTY
1	3530AY03-31Z514	SEAT ASSY, TPL LH IAT	1
2	3530AY03-32Z514	SEAT ASSY, TPL RH IAT	1
3	3530AY03-31Z314	SEAT ASSY, TPL LH STD	22
4	3530AY03-32Z314	SEAT ASSY, TPL RH STD	22
5	3530AY03-31Z474	SEAT ASSY, LH STD, NO COAT HOOK, TABLE LATCH OPENS I/B ONLY, NO RECLINE	1
6	3530AY03-32Z474	SEAT ASSY, RH STD, NO COAT HOOK, TABLE LATCH OPENS I/B ONLY, NO RECLINE	1
7	3530AY03-31Z334	SEAT ASSY, LH SPECIAL EXIT SEAT CUSHION, SPEC UPRIGHT, NO ARMREST O/B, NO COAT HOOK, NO RECLINE, TABLE LATCH OPEN I/B ONLY, FOLD ARMREST I/B, SPECIAL SEATBELT SHACKLE O/B	1
8	3530AY03-32Z334	SEAT ASSY, RH SPECIAL EXIT SEAT CUSHION, SPEC UPRIGHT, NO ARMREST O/B, NO COAT HOOK, NO RECLINE, TABLE LATCH OPEN I/B ONLY, FOLD ARMREST I/B, SPECIAL SEATBELT SHACKLE O/B	1
9	3530AY03-31Z344	SEAT ASSY, LH SPECIAL EXIT SEAT CUSHION, NO ARMREST O/B, FOLD ARMREST I/B, SPECIAL SEATBELT SHACKLE O/B	1
10	3530AY03-32Z344	SEAT ASSY, RH SPECIAL EXIT SEAT CUSHION, NO ARMREST O/B, FOLD ARMREST I/B, SPECIAL SEATBELT SHACKLE O/B	1
11	3530AY03-31Z444	SEAT ASSY, LH STD, STRETCHER	1
12	3530AY03-32Z444	SEAT ASSY, RH STD, STRETCHER	1
13	3530AY03-31Z384	SEAT ASSY, LH NARROW, STRETCHER	1
14	3530AY03-32Z384	SEAT ASSY, RH NARROW, STRETCHER	1
15	3530AY03-31Z354	SEAT ASSY, LH NARROW, NARROW BACKREST, STRETCHER, SHORT BAGGAGE BAR	1
16	3530AY03-32Z354	SEAT ASSY, RH NARROW, NARROW BACKREST, STRETCHER, SHORT BAGGAGE BAR	1
17	3530AY03-31Z364	SEAT ASSY, LH LAST ROW, NARROW, NARROW BACKREST, SLANTED SPREWADER O/B, STRETCHER, SHORT BAGGAGE BAR, NO TABLE, NO LIT POCKET, NO NETTING POCKET, NO COAT HOOK	1
18	3530AY03-32Z364	SEAT ASSY, RH LAST ROW, NARROW, NARROW BACKREST, SLANTED SPREWADER O/B, STRETCHER, SHORT BAGGAGE BAR, NO TABLE, NO LIT POCKET, NO NETTING POCKET, NO COAT HOOK	1

**DRAWING INFORMATION:**  
This drawing is property of AIRE SL. It is issued on the condition that it is not copied, reproduced or disclosed to a third party either whole or in part without the consent in writing of AIRE SL

		TITLE: LAYOUT OF PASSENGER ACCOMODATIONS	
		PREPARED BY: DESIGN OFFICE	REFERENCE: DWG-A320C234-002-LOPA
SIGNATURE ON SHEET 1		AIRCRAFT TYPE: AIRBUS A320-200	SHEET: 1/4 ISSUE: 1

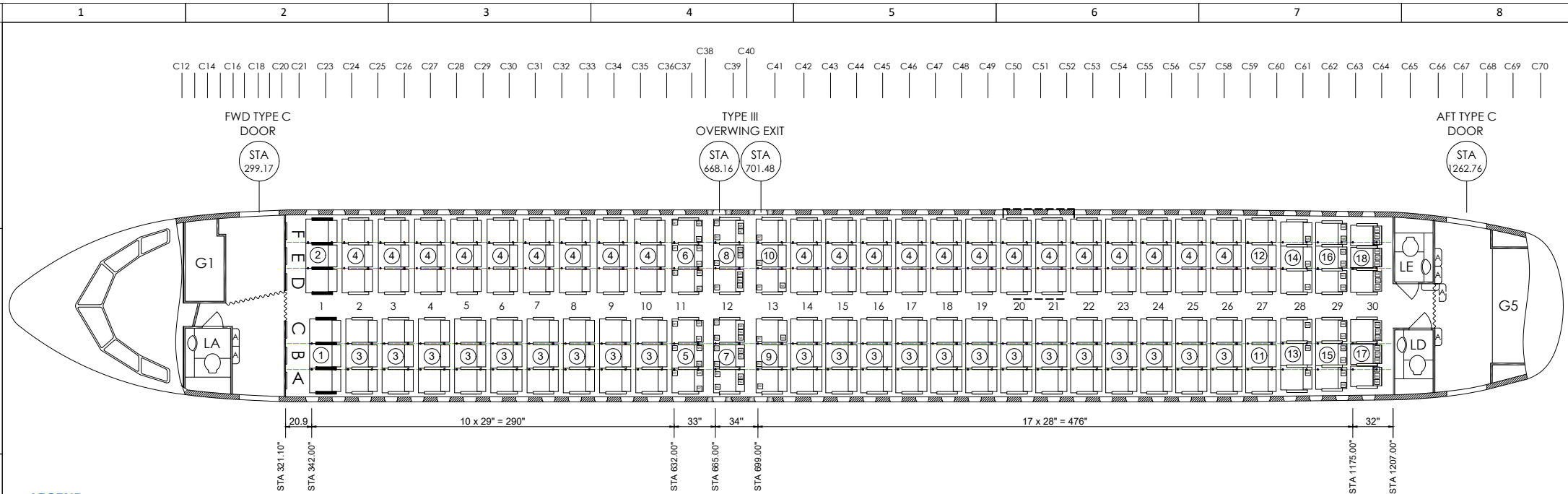

FIGURE 2-D1. LAYOUT OF PASSENGER ACCOMMODATIONS - 180 T/C

LEGEND

- SC SPEC.EXIT SEAT CUSHION
- ST SPEC. TABLE LATCH OPENS I/B ONLY
- NR NO RECLINE
- NC NO COAT HOOK
- NS NARROW SEAT
- NB NARROW BACKREST
- NA NO ARMREST O/B

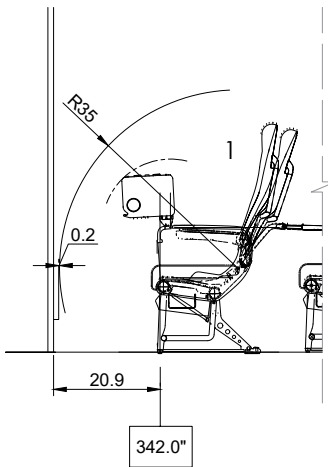

FIGURE 2-B2. MINIMUM REQUIRED BULKHEAD CLEARANCE

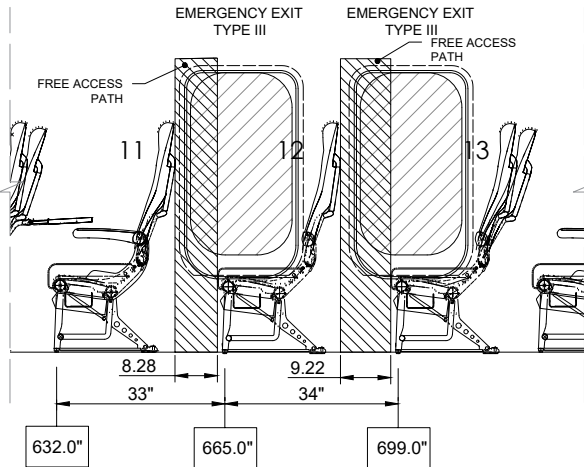

FIGURE 2-B4. EMERGENCY EXIT LATERAL VIEW - FREE ACCESS PATH

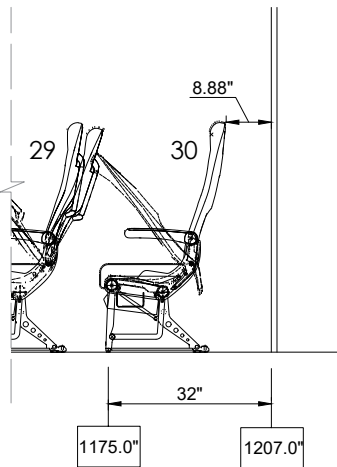
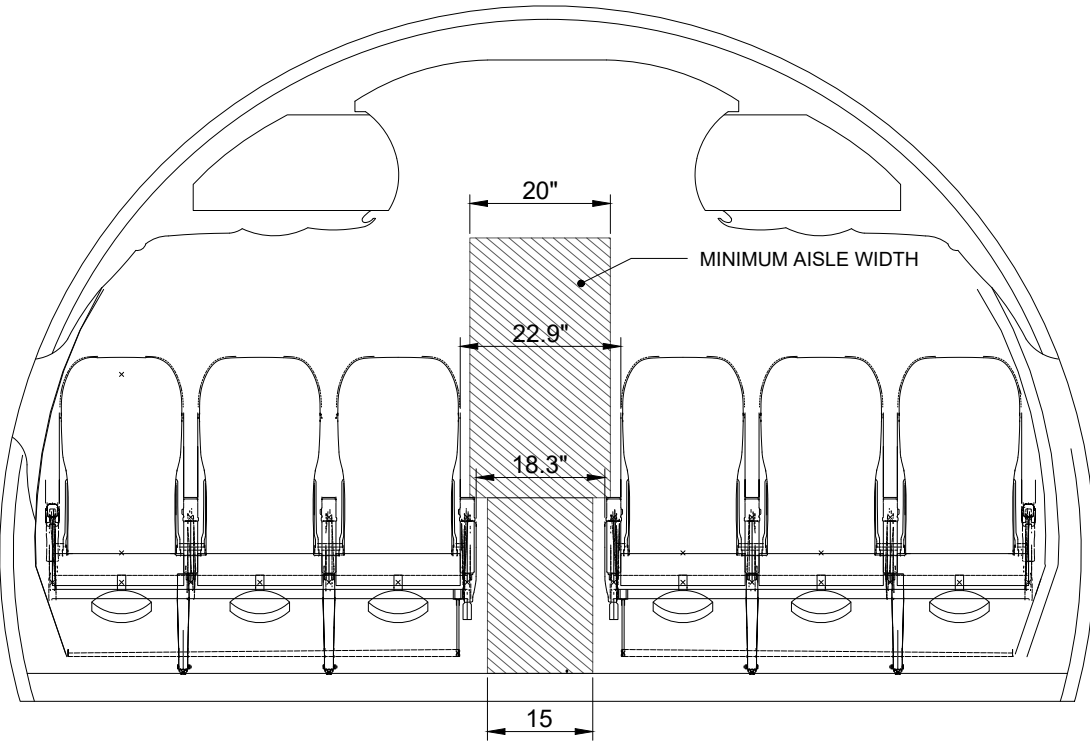

FIGURE 2-B4. LAST ROW DISTANCE TO LAVATORY

(REFER TO SHEET 1 FOR FURTHER INFORMATION)

DRAWING INFORMATION: This drawing is property of AIRE SL. It is issued on the condition that it is not copied, reproduced or disclosed to a third party either whole or in part without the consent in writing of AIRE SL		<b>TITLE:</b> LAYOUT OF PASSENGER ACCOMODATIONS	
PREPARED BY: DESIGN OFFICE	REFERENCE: DWG-A320C234-002-LOPA	DIM: in SCALE: N/A	
SIGNATURE ON SHEET 1	AIRCRAFT TYPE: AIRBUS A320-200	SHEET: 2/4 ISSUE: 1	



**FIGURE 3-C1. CONSTANT SECTION FRONT VIEW - MINIMUM AISLE WIDTH REQUIREMENTS, FRONT ROW SEATS**

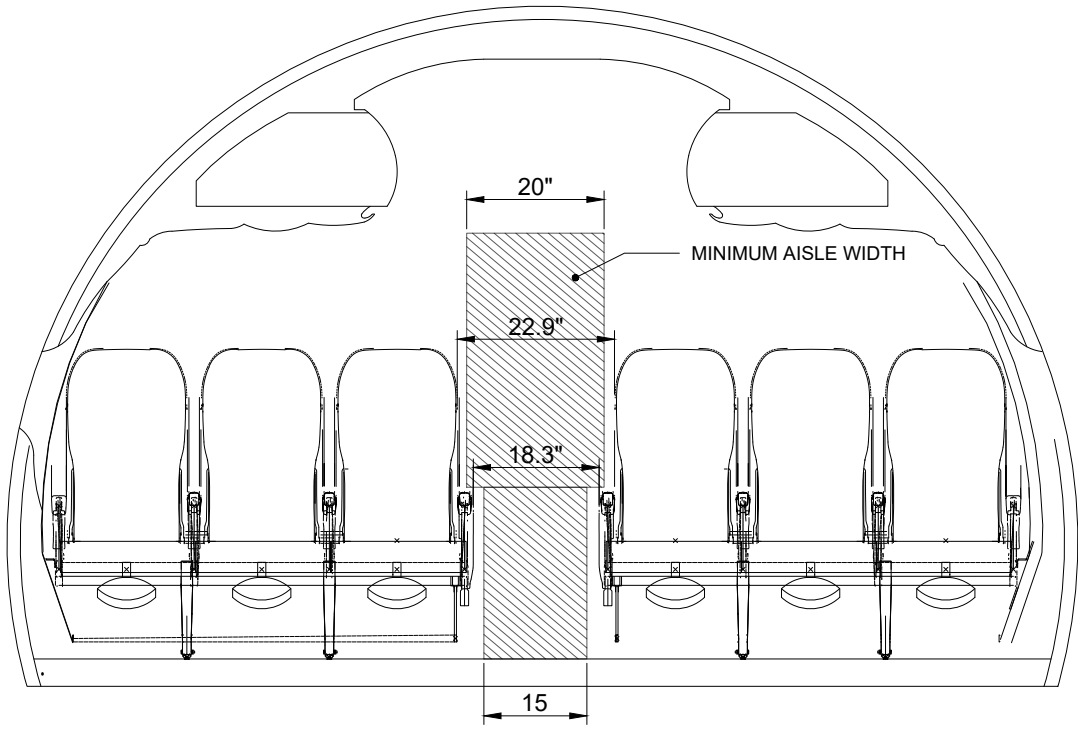

**FIGURE 3-C5. CONSTANT SECTION FRONT VIEW - MINIMUM AISLE WIDTH REQUIREMENTS, STD SEATS**

(REFER TO SHEET 1 FOR FURTHER INFORMATION)

<p><b>DRAWING INFORMATION:</b> This drawing is property of AIRE SL. It is issued on the condition that it is not copied, reproduced or disclosed to a third party either whole or in part without the consent in writing of AIRE SL</p>			<p><b>TITLE:</b> LAYOUT OF PASSENGER ACCOMODATIONS</p>
	<p><b>PREPARED BY:</b> DESIGN OFFICE</p>	<p><b>REFERENCE:</b> DWG-A320C234-002-LOPA</p>	<p><b>DIM:</b> in <b>SCALE:</b> N/A</p>
	<p><b>SIGNATURE</b> ON SHEET 1</p>	<p><b>AIRCRAFT TYPE:</b> AIRBUS A320-200</p>	<p><b>SHEET:</b> 3/4 <b>ISSUE:</b> 1</p>

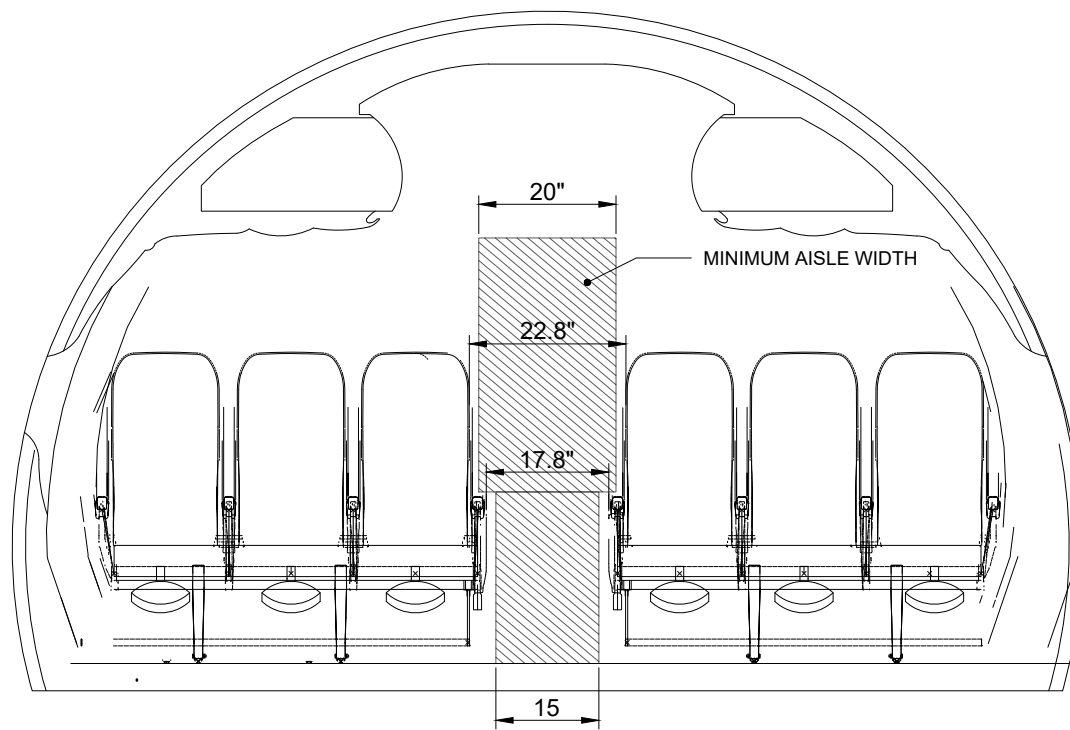

FIGURE 4-C3. CONSTANT SECTION FRONT VIEW - MINIMUM AISLE WIDTH REQUIREMENTS, LAST ROW SEATS

(REFER TO SHEET 1 FOR FURTHER INFORMATION)

**DRAWING INFORMATION:**  
 This drawing is property of AIRE SL. It is issued on the condition that it is not copied, reproduced or disclosed to a third party either whole or in part without the consent in writing of AIRE SL



**TITLE:**  
 LAYOUT OF PASSENGER ACCOMODATIONS

**PREPARED BY:**  
 DESIGN OFFICE

**REFERENCE:**  
 DWG-A320C234-002-LOPA

**DIM:** in  
**SCALE:** N/A

**SIGNATURE**  
 ON SHEET 1

**AIRCRAFT TYPE:**  
 AIRBUS A320-200

**SHEET:** 4/4  
**ISSUE:** 1