

**TABLE 2**

DESCRIPTION	ABBREVIATION
LEFT HAND	L/H
RIGHT HAND	R/H
CENTER	CTR
TRIPLE	TPL
DOUBLE	DBL
OUTBOARD	OUTBD
IN-ARM TABLE	IAT
RECLINE	REC
BREAKOVER	B/O
FOODTRAY	FDTR
LITERATURE POCKET	LP
NARROW	NRW
UPRIGHT	UPR
FORWARD	FWD
STANDARD	STD
TYPICAL	TYP
ASSEMBLY	ASSY
SPECIAL	SPCL
MOVABLE CLASS DIVIDER	MCD
SEAT REFERENCE POINT	SRP
CUSHION REFERENCE POINT	CRP
IN ACCORDANCE WITH	IAW











**NOTES:**

1. REMOVE/INSTALL PASSENGER SEATS IN ACCORDANCE WITH AMM SUPPLEMENT NO. JCAERO/AMM/1261-1.
2. THIS DRAWING TO BE READ IN CONJUNCTION WITH CHANGE ENGINEERING ORDER NO. JCAERO/EO/1261-1.
3. OUTBOARD ARMREST NOT TO PROTRUDE ACROSS EXIT APERTURE (THEREFORE IS TO BE A SHORT ARM OR NOT PRESENT) AND IS NOT TO IMPEDE OPENING OF EXIT HATCH. HATCH MOUNTED ARMRESTS (HMAR) ARE NOT ACCEPTABLE.
4. PASSENGER SEAT LOCATIONS REFER TO CENTERLINE OF THE SEAT FRONT STUD. THE CENTERLINE OF SEAT FRONT STUD TO BE DEFINED AS MEASUREMENT POINT.
5. ALL MEASUREMENTS SHALL BE MADE WITH SEATS IN UPRIGHT POSITION, ARMRESTS DOWN AND FOODTRAY TABLES STOWED.
6. FWD L/H & R/H WINDSCREENS ARE INSTALLED I.A.W. MINOR CHANGE NO. JCAERO/MODC/1264.

**FUNCTIONALITY AND CONFORMITY CHECKS**

7. CHECK THAT EXIT SIGNS/MARKERS ARE NOT OBSCURED.
8. CHECK THAT EACH SEAT IS EQUIPPED WITH AN (E)TSO APPROVED LIFE VEST.
9. CHECK THAT ALL "NO SMOKING" AND "FASTEN SEAT BELTS" SIGNS/MARKINGS ARE CLEARLY VISIBLE.
10. CHECK THAT OXYGEN DROP DOWN MASKS DEPLOY CORRECTLY I.A.W. THE AMM.
11. CHECK THAT THE TOTAL NUMBER OF OXYGEN MASKS EXCEEDS THE NUMBER OF PASSENGER SEATS BY 10%. THE EXTRA UNITS MUST BE EVENLY DISTRIBUTED THROUGHOUT THE CABIN AS PRACTICAL.
12. CHECK MINIMUM AISLE WIDTHS THROUGHOUT THE AIRCRAFT FOR CONFORMITY I.A.W. VIEW "SECTION A-A".
13. CHECK THAT SEAT ROW NUMBERING IS INSTALLED IN THE CORRECT LOCATIONS IAW AIPC AND MATCH THE NEW SEATING LAYOUT.
14. CHECK THAT EACH PASSENGER SEAT AND CREW SEAT IS EQUIPPED WITH (E)TSO APPROVED SEAT BELT I.A.W. APPLICABLE SEAT CMM.
15. CHECK THAT MINIMUM DISTANCE FROM CUSHION REFERENCE POINT TO BULKHEAD IS GREATER THAN 35.00 INCHES. THE CRP IS DEFINED AS THE INTERSECTION OF THE TOP SURFACE OF BOTTOM CUSHION AND A CONSIDERATIONS VERTICAL LINE TANGENTIAL TO THE FORWARD MOST POINT OF THE SEAT BACK. MEASURED AT THE CENTER OF THE SEAT BACK WITH THE SEAT BACK IN THE FULL UPRIGHT POSITION. LITERATURE POCKETS OR OTHER EQUIPMENT INSTALLED ON BULKHEADS AT 18 INCHES OR HIGHER ABOVE THE FLOOR LEVEL SHALL BE CONSIDERED WITHIN THE HEAD STRIKE AREA.
16. CHECK THAT MINIMUM TYPE III EMERGENCY EXIT PASSAGEWAY REQUIREMENTS CONFORM WITH VIEW "DETAIL C".
17. CHECK THAT TYPE III EXIT HATCHES OPERATE WITHOUT INTERFERENCE IAW THE AMM.
18. CHECK THAT ALL NEW SEATS ARE SUPPLIED WITH AN EASA FORM 1.
19. CHECK THAT ALL FLOOR PATH LIGHTING IS VISIBLE WHEN ALL CABIN LIGHTING ABOVE 4 FEET IS EXTINGUISHED INCLUDING EXIT SPURS.
20. CHECK THAT THERE IS A MINIMUM OF 0.79 INCH CLEARANCE BETWEEN THE SEAT BACKREST AND FIXED MONUMENT, AND BETWEEN THE SEAT AND SIDEWALL.
21. CHECK THAT FOODTRAY TABLES ON TYPE III OVERWING EXIT SEATS CANNOT BE INADVERTENTLY DEPLOYED INTO THE EMERGENCY EXIT AISLE. ONE OF THE FOLLOWING FEATURES MUST BE MET:
  - 21.1. FOODTRAY TABLE LATCHES OPERATE IN AN INBOARD DIRECTION ONLY, OR;
  - 21.2. FOODTRAY TABLE LATCHES ARE FULLY RECESSED BELOW THE SURROUNDING SEAT STRUCTURE.
22. CHECK THAT SEATS AT TYPE III OVER WING EMERGENCY EXITS DO NOT HAVE RECLINE OR BREAK OVER WHICH CAN INTERFERE WITH MINIMUM EMERGENCY EXIT AISLE WIDTHS AND DO NOT HAVE OUTBOARD ARMREST.
23. CHECK THAT ALL SEATS ARE EQUIPPED WITH APPROVED CUSHIONS AND COVERS AS PER SEAT CMM.
24. CHECK THAT EACH TYPE C EXIT HAVE ASSIST SPACE OF 12.00 x 20.00 INCHES AT ONE SIDE OF EXIT PASSAGEWAY ONLY. ASSIST SPACE MUST NOT INTERFERE WITH EXIT PASSAGEWAY.
25. CHECK THAT ALL SEATS PLACARDED WITH INSTRUCTIONS TO FASTEN SEAT BELTS AND WITH INFORMATION OF LIFE VEST LOCATION.
26. CHECK THAT PLACARDS CLEARLY INDICATED THE METHOD OF OPENING OF EACH TYPE III EXIT HATCH ARE LOCATED IN A PROMINENT POSITION & CLEARLY VISIBLE TO THE OCCUPANT OF EACH SEAT WHICH FORMS THE ACCESS ROUTE FROM THE CABIN AISLE TO THE TYPE III EXIT; ENSURE PRESENCE OF TYPE III HATCH OPENING INSTRUCTIONS PLACARD ON THE AFT FACE OF EACH FOODTRAY TABLE OR BACKREST OF THE SEATS IN ROW 11 AND 12 (PLACARDS ARE VISIBLE TO THE PASSENGERS IN ROW 12 AND 13)

**TABLE 1**

SYMBOL	DESCRIPTION	ABBREVIATION
	SEAT WITH IN-ARM TABLE	IAT
	LITERATURE POCKET	LP
	SEAT WITH NO ARMREST	NO ARM
	SEAT WITH NO FOODTRAY	NO FDTR
	SEAT WITH NO BREAK OVER	NO B/O
	SEAT WITH NO RECLINE	NO REC
	SEAT WITH HANDICAPPED FACILITIES	H
	CABIN ATTENDANT SEAT	CAS
	LAVATORY '(') - DESIGNATION LETTER	LAV
	GALLEY '(') - DESIGNATION DIGIT	GL

 <b>J&amp;C AERO</b> EEU <small>EASA APPROVAL NO: EASA.213.580</small>	WWW.THISISDOA.EU INFO@THISISDOA.EU PHONE: +353 15 269768	AIRCRAFT: <b>AIRBUS A320-214</b>	MANUFACTURING TOLERANCES: SHEET WORK: ±0.03 MACHINING: ±0.02 ANGULAR: ±0.50 (UNLESS OTHERWISE SPECIFIED)	DRAWN BY: <b>SEE JCAERO/ECN/2575</b>
	MSN: <b>03215</b>	REGISTRATION: <b>-</b>	SCALE: SIZE: <b>NTS A2</b>	CHECKED BY: <b>SEE JCAERO/ECN/2575</b>
	TITLE: <b>180 PAX [180Y] LAYOUT OF PASSENGER ACCOMMODATION</b>			
	DRAWING NUMBER: <b>P2G252JCAERO2575</b>		SHEET 1 OF 4	

DRAWING NUMBER:  
P2G252JCAERO2575

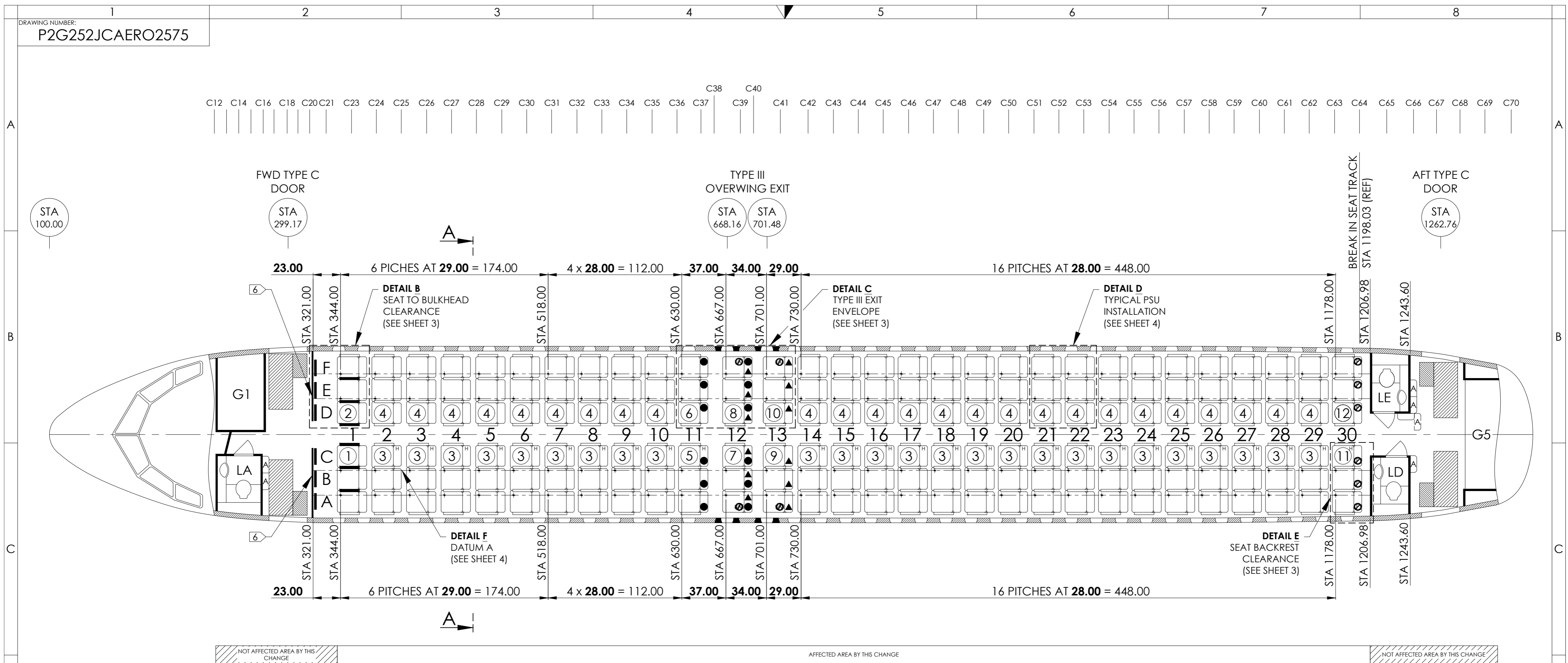

1 -101 INSTALLATION

QTY.	MAP REF.	ITEM NO.	PART NUMBER	DESCRIPTION	MANU.	CMM	STATUS	NOTE
1		12	3510A364-32-052	R/H TRIPLE SEAT - NO FDTR	RECARO	25-25-94	NEW	
1		11	3510A364-31-052	L/H TRIPLE SEAT - NO FDTR	RECARO	25-25-94	NEW	
1		10	3510A364-32-242	R/H TRIPLE SEAT - NO OUTBD ARM	RECARO	25-25-94	NEW	
1		9	3510A364-31-242	L/H TRIPLE SEAT - NO OUTBD ARM	RECARO	25-25-94	NEW	
1		8	3510A364-32-232	R/H TRIPLE SEAT - NO REC, NO OUTBD ARM, SPCL UPR 22.32", SPCL TABLE LATCH	RECARO	25-25-94	NEW	
1		7	3510A364-31-232	L/H TRIPLE SEAT - NO REC, NO OUTBD ARM, SPCL UPR 22.32", SPCL TABLE LATCH	RECARO	25-25-94	NEW	
1		6	3510A364-32-022	R/H TRIPLE SEAT - NO REC, SPCL TABLE LATCH	RECARO	25-25-94	NEW	
1		5	3510A364-31-022	L/H TRIPLE SEAT - NO REC, SPCL TABLE LATCH	RECARO	25-25-94	NEW	
25		4	3510A364-32-012	R/H TRIPLE SEAT - STD	RECARO	25-25-94	NEW	
25		3	3510A364-31-012	L/H TRIPLE SEAT - STD	RECARO	25-25-94	NEW	
1		2	3510A364-32-212	R/H TRIPLE SEAT - IAT	RECARO	25-25-94	NEW	
1		1	3510A364-31-212	L/H TRIPLE SEAT - IAT	RECARO	25-25-94	NEW	
180 PAX [180Y] LAYOUT OF PASSENGER ACCOMMODATION								
OR REMARKS								

<p>J&amp;C AERO EEU EASA APPROVAL NO: EASA.211.580</p>	<p>WWW.THISDOA.EU INFO@THISDOA.EU PHONE: +353 15 269768</p>	<p>AIRCRAFT: AIRBUS A320-214</p>	<p>MANUFACTURING TOLERANCES: SHEET WORK: ±0.03 MACHINING: ±0.02 ANGULAR: ±0.50 (UNLESS OTHERWISE SPECIFIED)</p>	<p>DRAWN BY: SEE JCAERO/ECN/2575</p>	
	<p>MSN: 03215</p>	<p>REGISTRATION: -</p>	<p>SCALE: NTS SIZE: A2</p>	<p>ALL DIMENSIONS ARE IN INCHES THIRD ANGLE PROJECTION</p>	<p>CHECKED BY: SEE JCAERO/ECN/2575</p>
	<p>TITLE: 180 PAX [180Y] LAYOUT OF PASSENGER ACCOMMODATION</p>				
	<p>DRAWING NUMBER: P2G252JCAERO2575</p>			<p>SHEET 2 OF 4</p>	



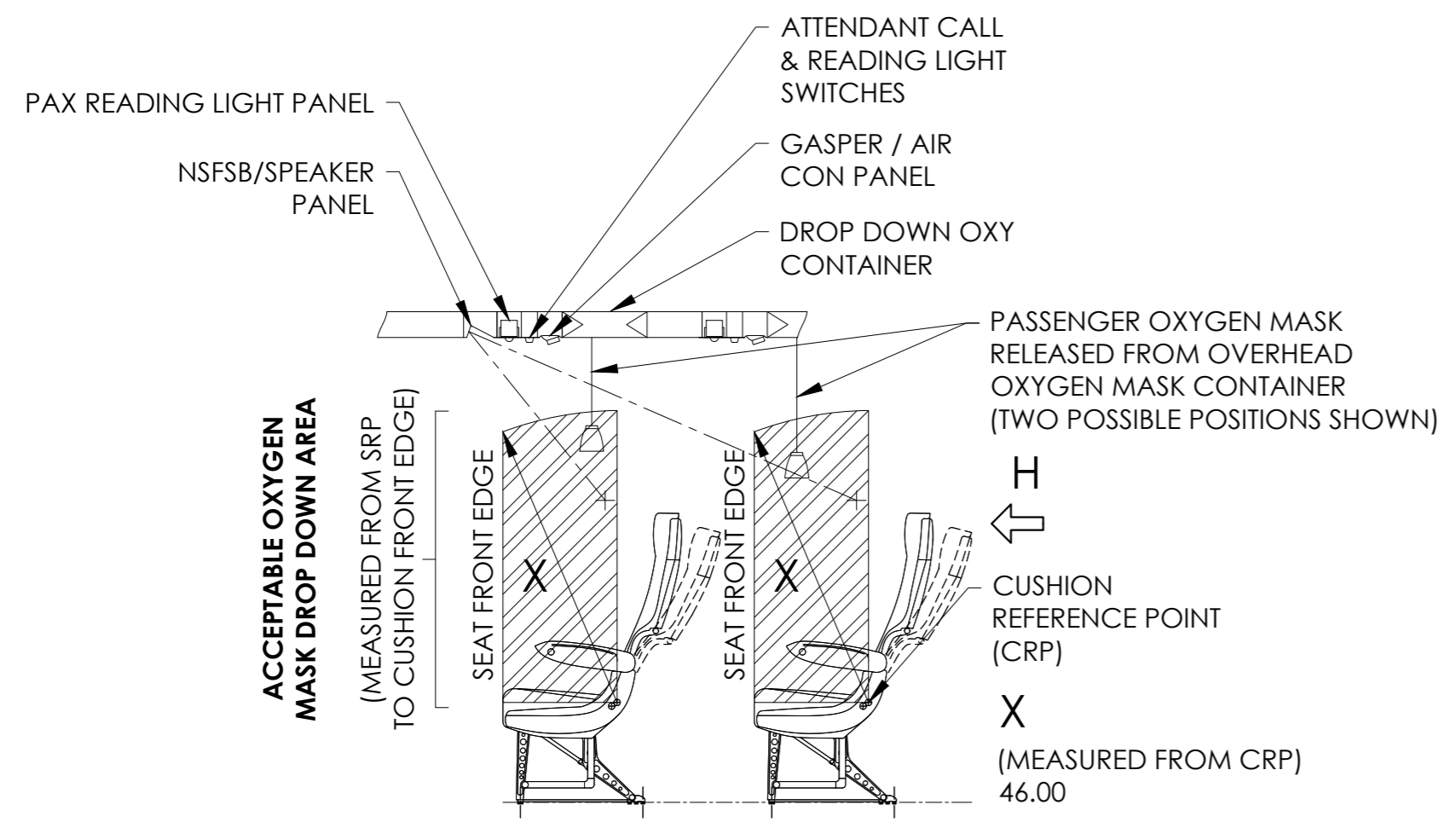

**DETAIL D**  
TYPICAL PSU/PSIU ARRANGEMENT

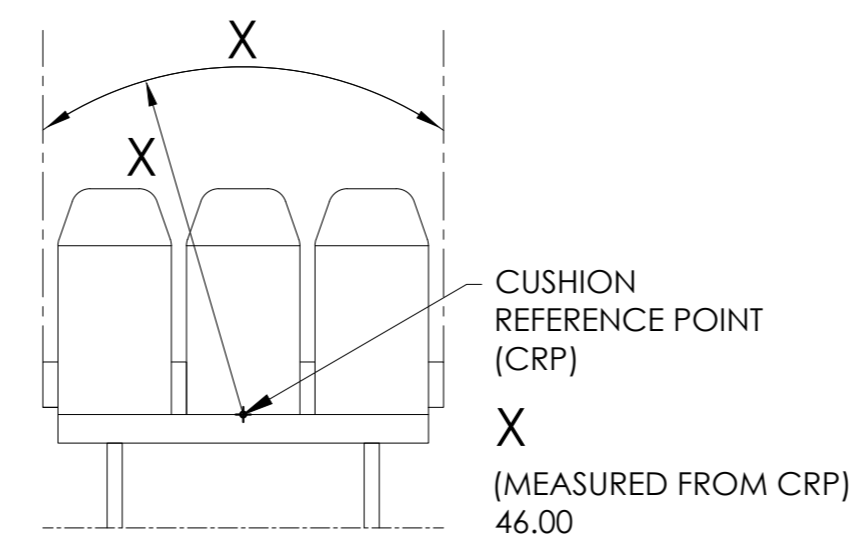

**VIEW ON ARROW H**  
TYPICAL OXYGEN MASK DROP DOWN RADIUS

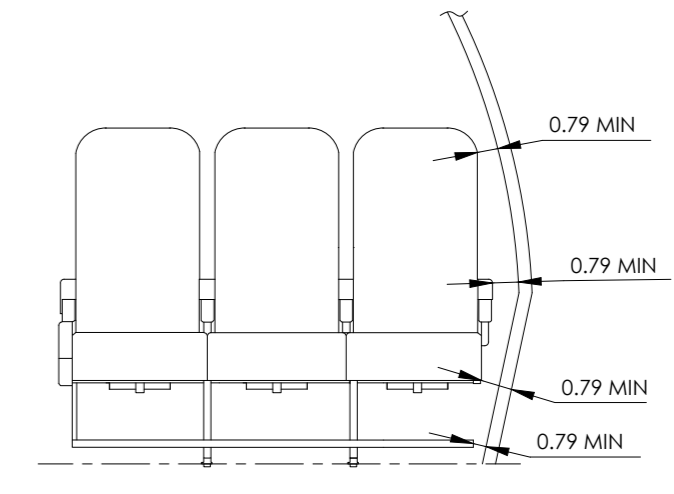

**MINIMUM CLEARANCE FROM THE SIDEWALL**  
IAW AIRBUS FRAME SPECIFICATION  
NO. 2521 M1F 1000 00

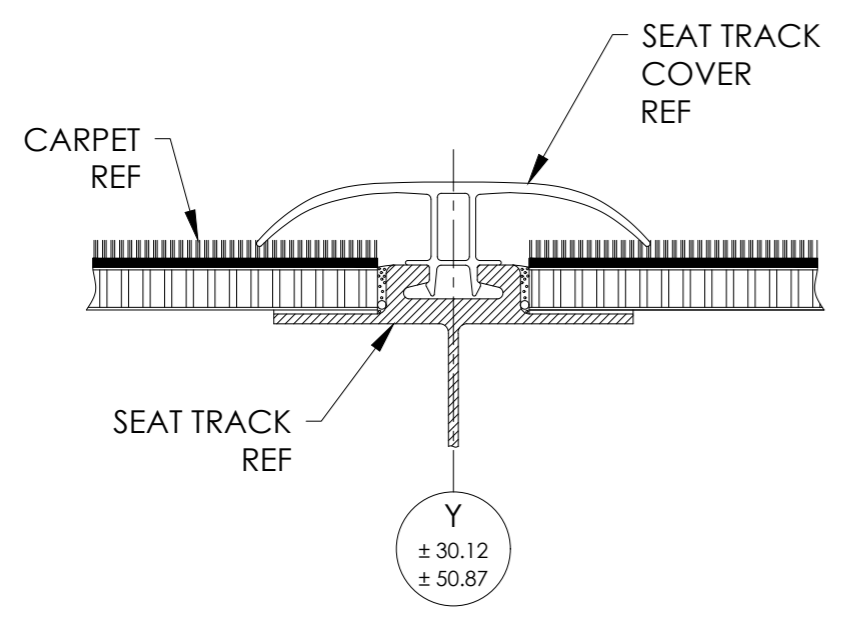

**TYPICAL SEAT TRACK COVER INSTALLATION**

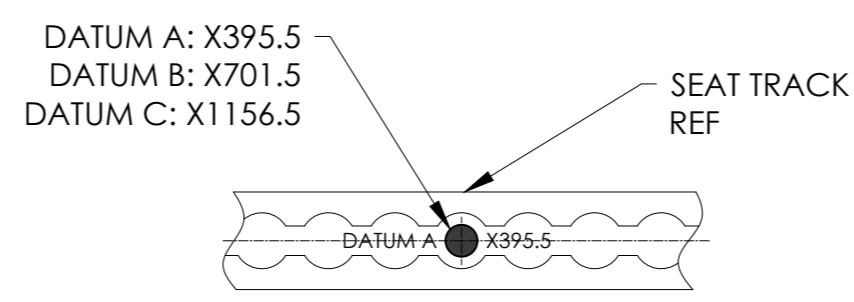

**DETAIL F**  
DATUM A

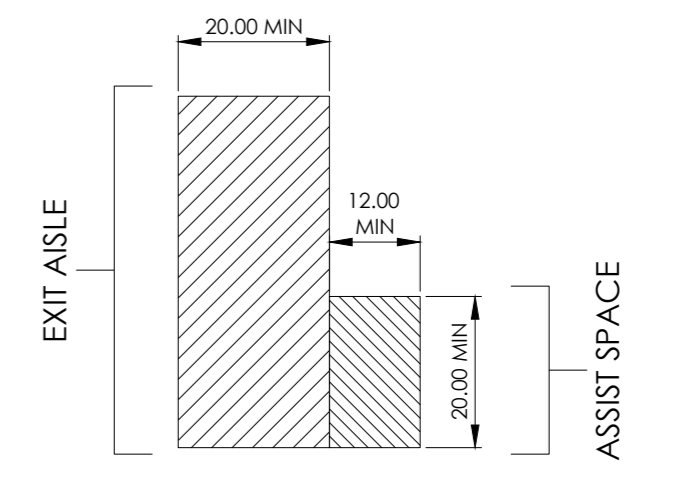

**TYPICAL TYPE I, TYPE C DOOR EXIT AISLE & ASSIST SPACE**  
(REFER TO JAR 25.813 EMERGENCY EXIT ACCESS AND EASE OF OPERATION)

 J&C AERO EEU <small>EASA APPROVAL NO.: EASA.211.580</small>	<small>WWW.THISDOA.EU</small> <small>INFO@THISDOA.EU</small> <small>PHONE: +353 15 269768</small>	<small>AIRCRAFT:</small> AIRBUS A320-214	<small>MANUFACTURING TOLERANCES:</small> SHEET WORK: ±0.03 MACHINING: ±0.02 ANGULAR: ±0.50 (UNLESS OTHERWISE SPECIFIED)	<small>DRAWN BY:</small> SEE JCAERO/ECN/2575	
	<small>MSN:</small> 03215	<small>REGISTRATION:</small> -	<small>SCALE:</small> NTS	<small>SIZE:</small> A2	<small>CHECKED BY:</small> SEE JCAERO/ECN/2575
	<small>TITLE:</small> 180 PAX [180Y] LAYOUT OF PASSENGER ACCOMMODATION				
	<small>DRAWING NUMBER:</small> P2G252JCAERO2575			<small>SHEET 4 OF 4</small>	<small>REV. A</small>